

1. Description

BL23N50, the silicon N-channel Enhanced MOSFETs, is obtained by advanced MOSFET technology which reduce the conduction loss, improve switching performance and enhance the avalanche energy. The transistor is suitable device for SMPS, high speed switching and general purpose applications.

KEY CHARACTERISTICS

| Parameter | Value | Unit |
|------------------|-------|----------|
| $V_{DS@Tj,max}$ | 500 | V |
| I_D | 23 | A |
| $R_{DS(ON).Typ}$ | 0.22 | Ω |

FEATURES

- Fast Switching
- Low C_{rss}
- 100% avalanche tested
- Improved dv/dt capability
- RoHS product

APPLICATIONS

- High frequency switching mode power supply

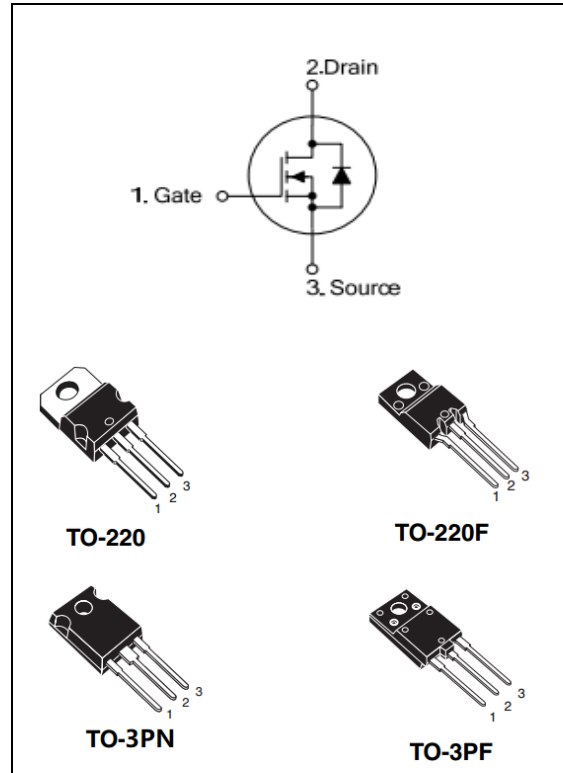

ORDERING INFORMATION

| Ordering Codes | Package | Product Code | Packing |
|----------------|---------|--------------|---------|
| BL23N50-P | TO-220 | BL23N50 | Tube |
| BL23N50-A | TO-220F | | Tube |
| BL23N50-W | TO-3PN | | Tube |
| BL23N50-K | TO-3PF | | Tube |

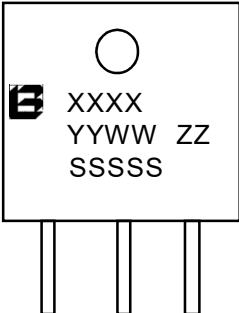
| | |
|---|---|
| <p>BL23N50-A</p> <div style="border: 1px solid black; padding: 5px; margin: 10px 0;"> <p>(2) Package type</p> <p>(1) Chip name</p> </div> <p>(1) BL23N50:500V 23A (2) A:TO-220F P:TO-220 W:TO-3PN K:TO-3PF</p> |  <p>XXXX: Product Code YYWW: Year&Week ZZ: Assembly Code SSSSS: Lot Code</p> |
|---|---|

2. ABSOLUTE RATINGS

at $T_C = 25^\circ\text{C}$, unless otherwise specified

| Symbol | Parameter | Rating | Units |
|----------------|--|-------------------|---------------------|
| V_{DSS} | Drain-to-Source Voltage | 500 | V |
| I_D | Continuous Drain Current | 23 | A |
| | Continuous Drain Current $T_C = 100^\circ\text{C}$ | 14.5 | A |
| I_{DM} | Pulsed Drain Current(Note1) | 92 | A |
| V_{GS} | Gate-to-Source Voltage | ± 30 | V |
| E_{AS} | Single Pulse Avalanche Energy(Note2) | 1500 | mJ |
| dv/dt | Peak Diode Recovery dv/dt (Note3) | 5.0 | V/ns |
| P_D | Power Dissipation TO-220, TO-3PN | 271 | W |
| | Derating Factor above 25°C | 2.18 | W/ $^\circ\text{C}$ |
| P_D | Power Dissipation TO-220F, TO-3PF | 50 | W |
| | Derating Factor above 25°C | 0.4 | W/ $^\circ\text{C}$ |
| T_J, T_{stg} | Operating Junction and Storage Temperature Range | 150, -55 to 150 | $^\circ\text{C}$ |
| T_L | Maximum Temperature for Soldering | 300 | $^\circ\text{C}$ |

3. Thermal characteristics

Thermal characteristics (No FullPAK) TO-220\TO-3PN

| Symbol | Parameter | RATINGS | Units |
|-----------------|---------------------|---------|---------------------------|
| $R_{\theta JC}$ | Junction-to-Case | 0.46 | $^\circ\text{C}/\text{W}$ |
| $R_{\theta JA}$ | Junction-to-Ambient | 62.5 | $^\circ\text{C}/\text{W}$ |

Thermal characteristics (FullPAK) TO-220F\TO-3PF

| Symbol | Parameter | RATINGS | Units |
|-----------------|---------------------|---------|---------------------------|
| $R_{\theta JC}$ | Junction-to-Case | 2.5 | $^\circ\text{C}/\text{W}$ |
| $R_{\theta JA}$ | Junction-to-Ambient | 62.5 | $^\circ\text{C}/\text{W}$ |

4. Electrical Characteristics

 at $T_C = 25^\circ\text{C}$, unless otherwise specified

| OFF Characteristics | | | | | | |
|------------------------------|-----------------------------------|---|--------|------|------|--------------------|
| Symbol | Parameter | Test Conditions | Values | | | Units |
| | | | Min. | Typ. | Max. | |
| V_{DSS} | Drain to Source Breakdown Voltage | $V_{GS}=0V$, $I_D=250\mu A$ | 500 | -- | -- | V |
| $\Delta BV_{DSS}/\Delta T_J$ | Bvdss Temperature Coefficient | $I_D=250\mu A$, Reference 25°C | -- | 0.63 | -- | $V/^\circ\text{C}$ |
| I_{DSS} | Drain to Source Leakage Current | $V_{DS}=500V$, $V_{GS}=0V$, $T_J=25^\circ\text{C}$ | -- | -- | 1 | μA |
| | | $V_{DS}=400V$, $V_{GS}=0V$, $T_J=125^\circ\text{C}$ | -- | -- | 100 | μA |
| $I_{GSS(F)}$ | Gate to Source Forward Leakage | $V_{GS}=+30V$ | -- | -- | 100 | nA |
| $I_{GSS(R)}$ | Gate to Source Reverse Leakage | $V_{GS}=-30V$ | -- | -- | -100 | nA |

| ON Characteristics | | | | | | |
|--------------------|-------------------------------|---|--------|------|------|----------|
| Symbol | Parameter | Test Conditions | Values | | | Units |
| | | | Min. | Typ. | Max. | |
| $R_{DS(ON)}$ | Drain-to-Source On-Resistance | $V_{GS}=10V$, $I_D=11.5A(\text{Note4})$ | -- | 0.22 | 0.26 | Ω |
| $V_{GS(TH)}$ | Gate Threshold Voltage | $V_{DS}=V_{GS}$, $I_D=250\mu A(\text{Note4})$ | 2.0 | -- | 4.0 | V |
| g_{fs} | Forward Transconductance | $V_{DS}=15V$, $I_D=11.5A(\text{Note4})$ | -- | 12 | -- | S |

| Dynamic Characteristics | | | | | | |
|-------------------------|------------------------------|--|--------|------|------|----------|
| Symbol | Parameter | Test Conditions | Values | | | Units |
| | | | Min. | Typ. | Max. | |
| R_g | Gate resistance | $f=1.0\text{MHz}$ | -- | 1.5 | -- | Ω |
| C_{iss} | Input Capacitance | $V_{GS}=0V$ $V_{DS}=25V$ $f=1.0\text{MHz}$ | -- | 3774 | -- | PF |
| C_{oss} | Output Capacitance | | -- | 279 | -- | |
| C_{rss} | Reverse Transfer Capacitance | | -- | 3 | -- | |

| Switching Characteristics | | | | | | |
|---------------------------|---------------------------------|---|--------|------|------|-------|
| Symbol | Parameter | Test Conditions | Values | | | Units |
| | | | Min. | Typ. | Max. | |
| $t_{d(ON)}$ | Turn-on Delay Time | ID =23A VDD = 250V VGS = 10V RG =20Ω | -- | 35 | -- | ns |
| t_r | Rise Time | | -- | 78 | -- | |
| $t_{d(OFF)}$ | Turn-Off Delay Time | | -- | 96 | -- | |
| t_f | Fall Time | | -- | 80 | -- | |
| Q_g | Total Gate Charge | ID =23A VDD =400V VGS = 10V | -- | 61 | -- | nC |
| Q_{gs} | Gate to Source Charge | | -- | 19 | -- | |
| Q_{gd} | Gate to Drain ("Miller") Charge | | -- | 15 | -- | |

| Source-Drain Diode Characteristics | | | | | | |
|------------------------------------|--|---|--------|------|------|-------|
| Symbol | Parameter | Test Conditions | Values | | | Units |
| | | | Min. | Typ. | Max. | |
| I_S | Continuous Source Current (Body Diode) | TC=25 °C | -- | -- | 23 | A |
| I_{SM} | Maximum Pulsed Current (Body Diode) | | -- | -- | 92 | A |
| V_{SD} | Diode Forward Voltage | IS=23A, VGS=0V(Note4) | -- | -- | 1.2 | V |
| T_{rr} | Reverse Recovery Time | IS=23A, Tj = 25°C dIF/dt=100A/us, VGS=0V | -- | 536 | -- | ns |
| Q_{rr} | Reverse Recovery Charge | | -- | 6191 | -- | nC |
| I_{rrm} | Reverse Recovery Current | | -- | 23.1 | -- | A |

Note1: Pulse width limited by maximum junction temperature

Note2: L=10mH, VD_s=50V, Start T_J=25°C

Note3: ISD =23A, di/dt ≤100A/us, VDD≤BVDS, Start T_J=25°C

Note4: Pulse width tp≤300μs, δ≤2%

5. Characteristics Curves

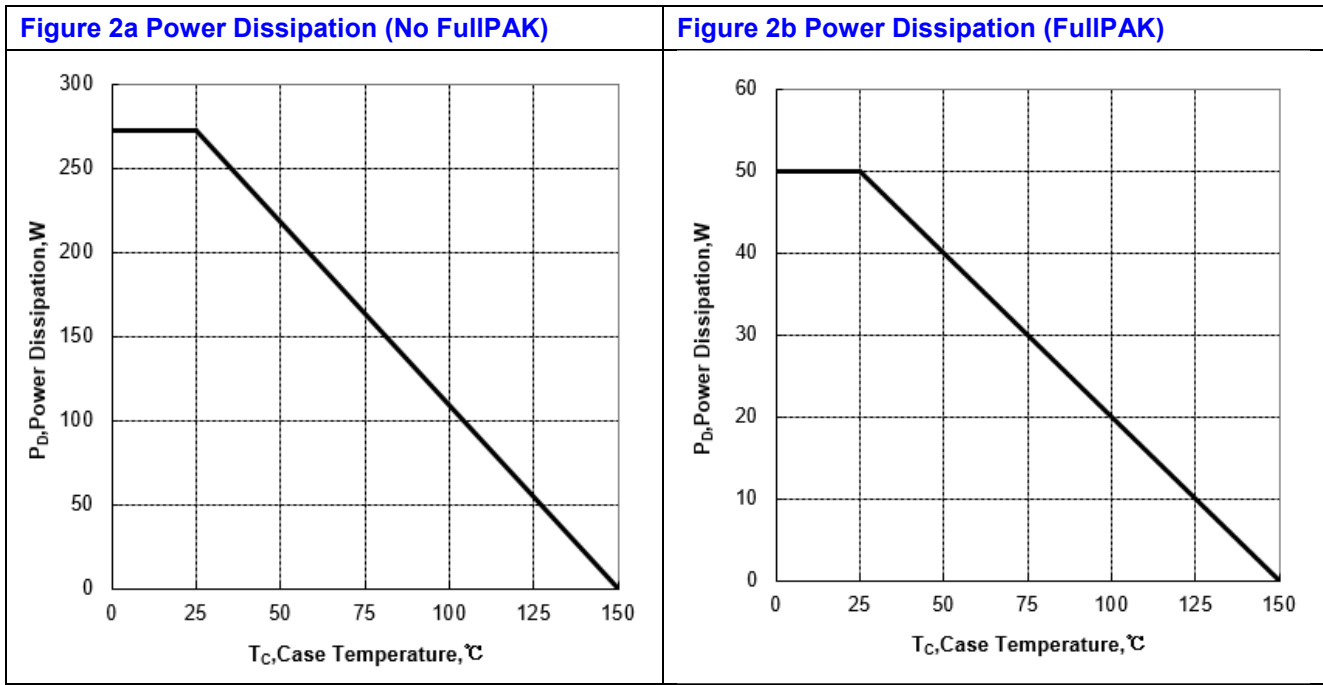
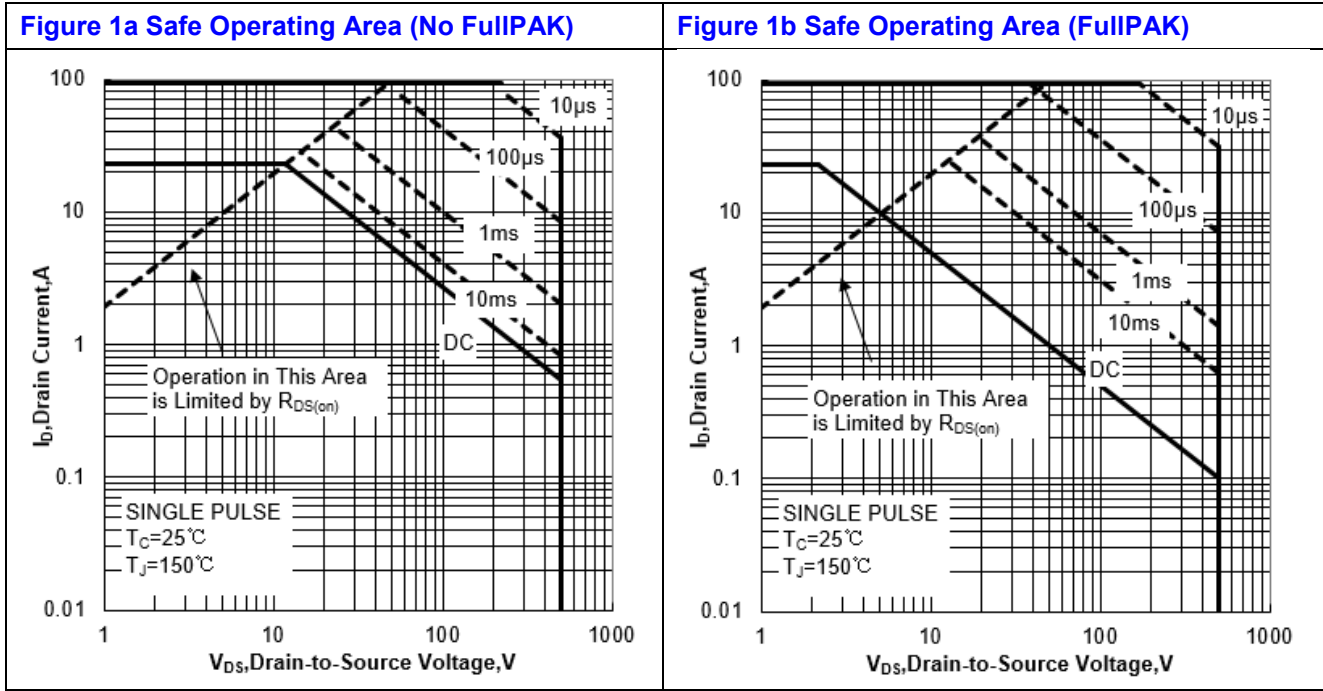

Figure 3a Max Thermal Impedance (No FullPAK)

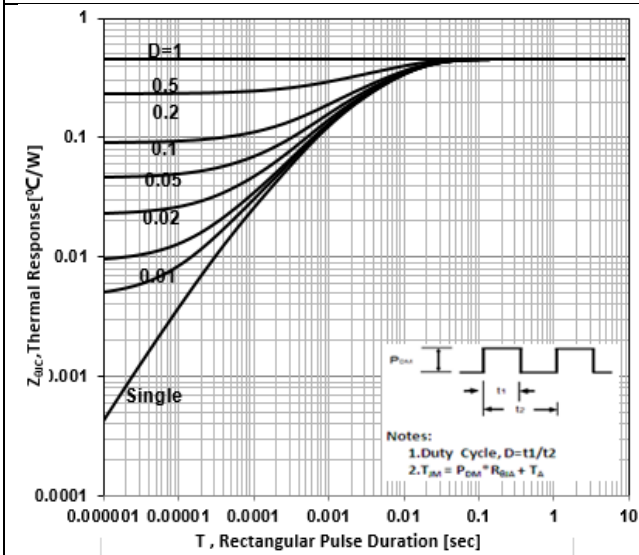

Figure 3b Max Thermal Impedance (FullPAK)

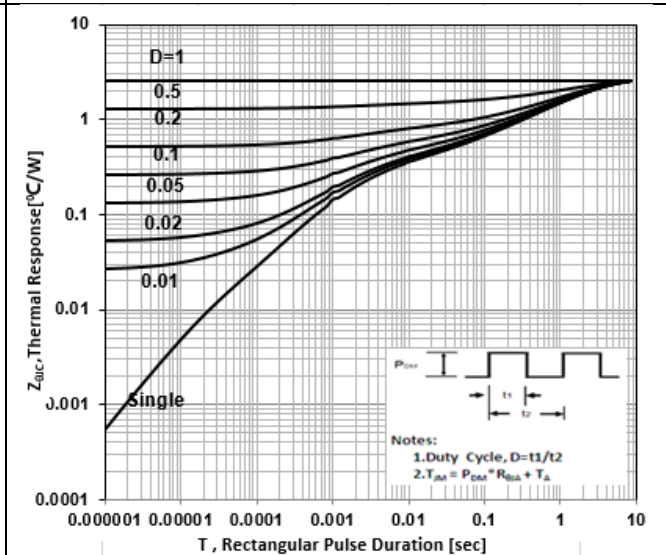

Figure 4 Typical Output Characteristics

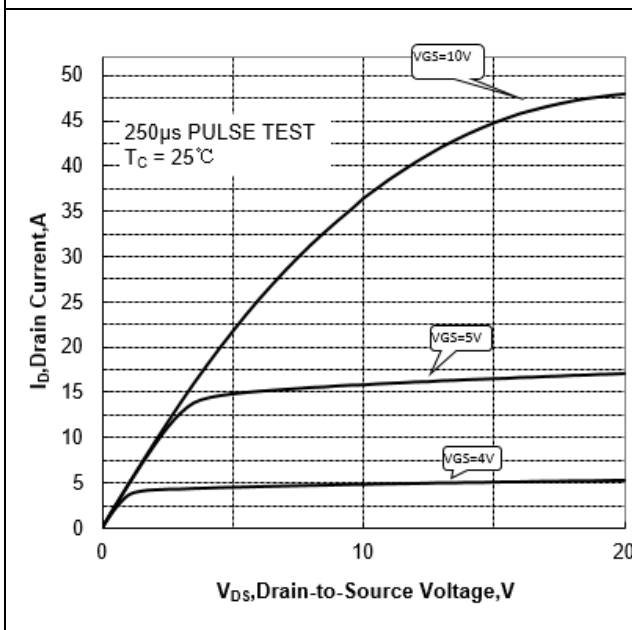

Figure 5 Typical Transfer Characteristics

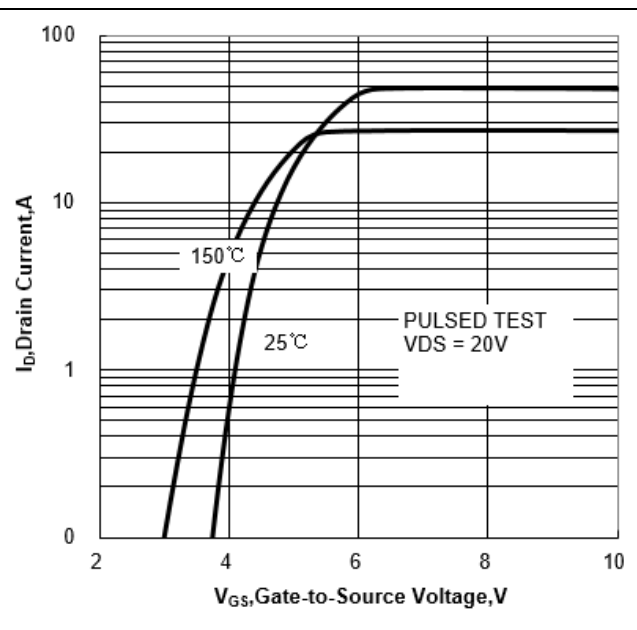

Figure 6 Typical Drain to Source ON Resistance vs Drain Current

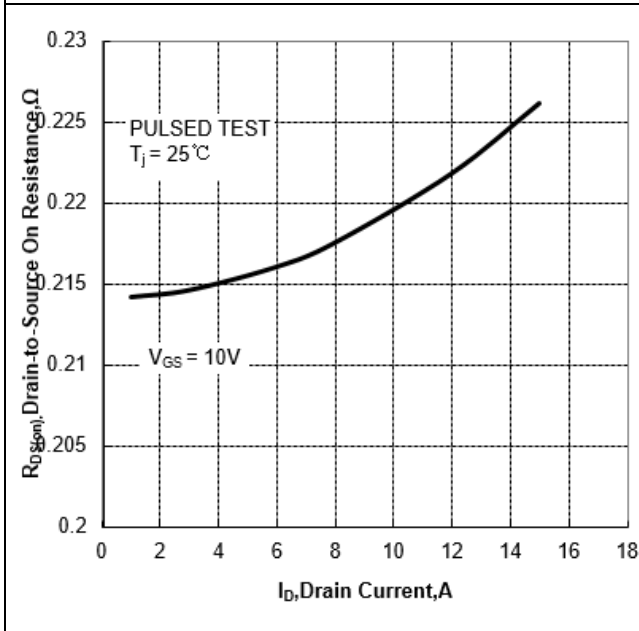

Figure 7 Typical Drain to Source on Resistance vs Junction Temperature

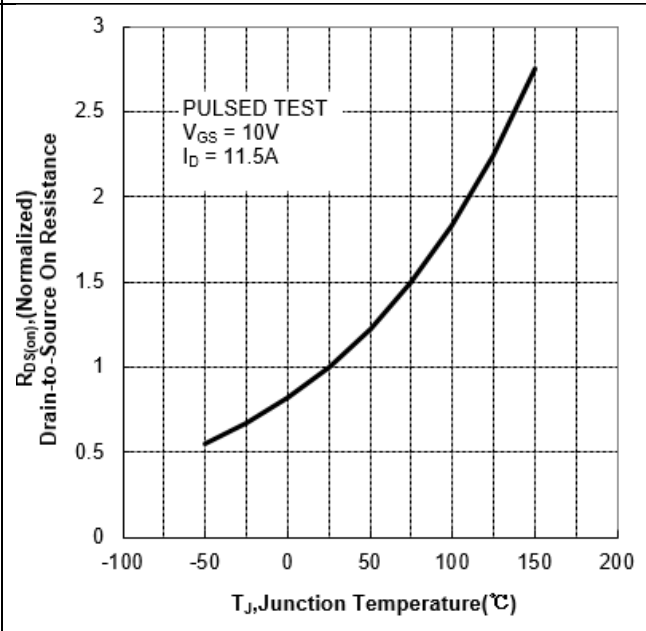

Figure 8 Typical Threshold Voltage vs Junction Temperature

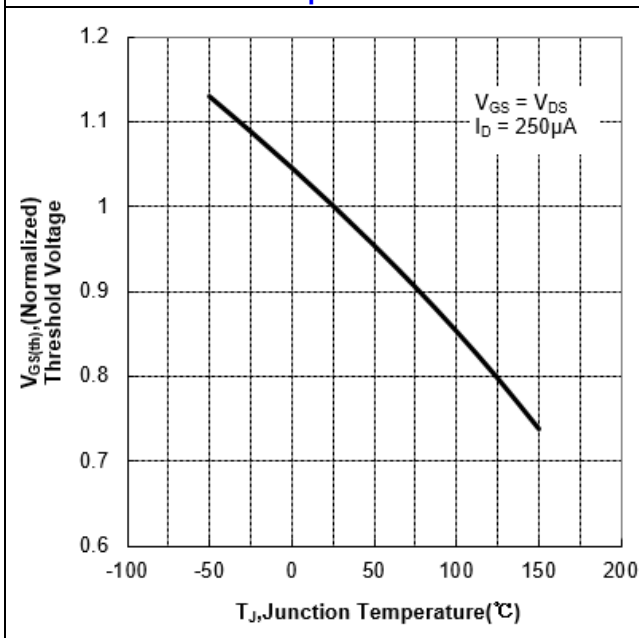

Figure 9 Typical Breakdown Voltage vs Junction Temperature

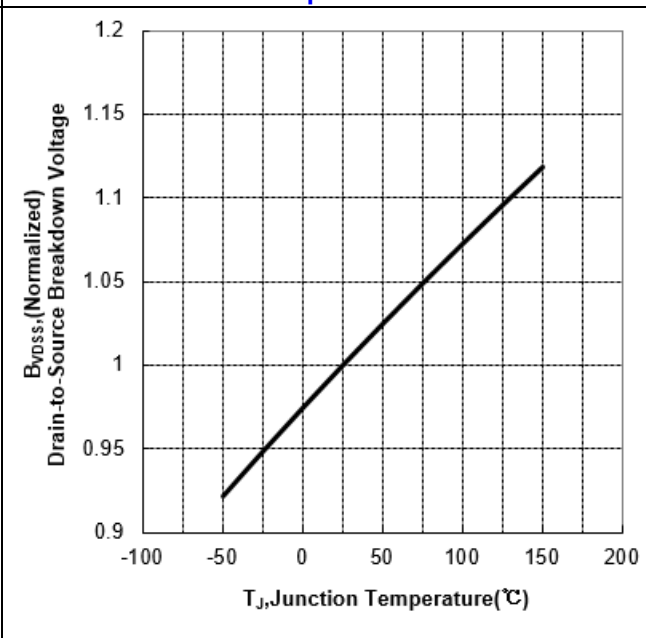

Figure 10 Capacitance Characteristics

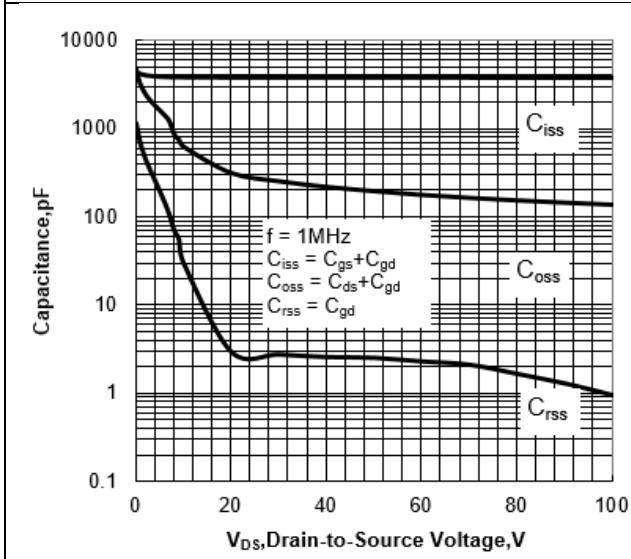
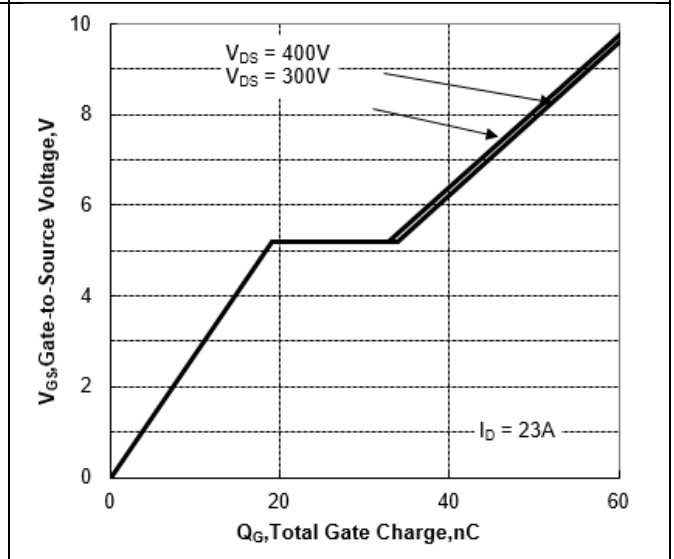

Figure 11 Gate Charge Characteristics



6. Test Circuit and Waveform

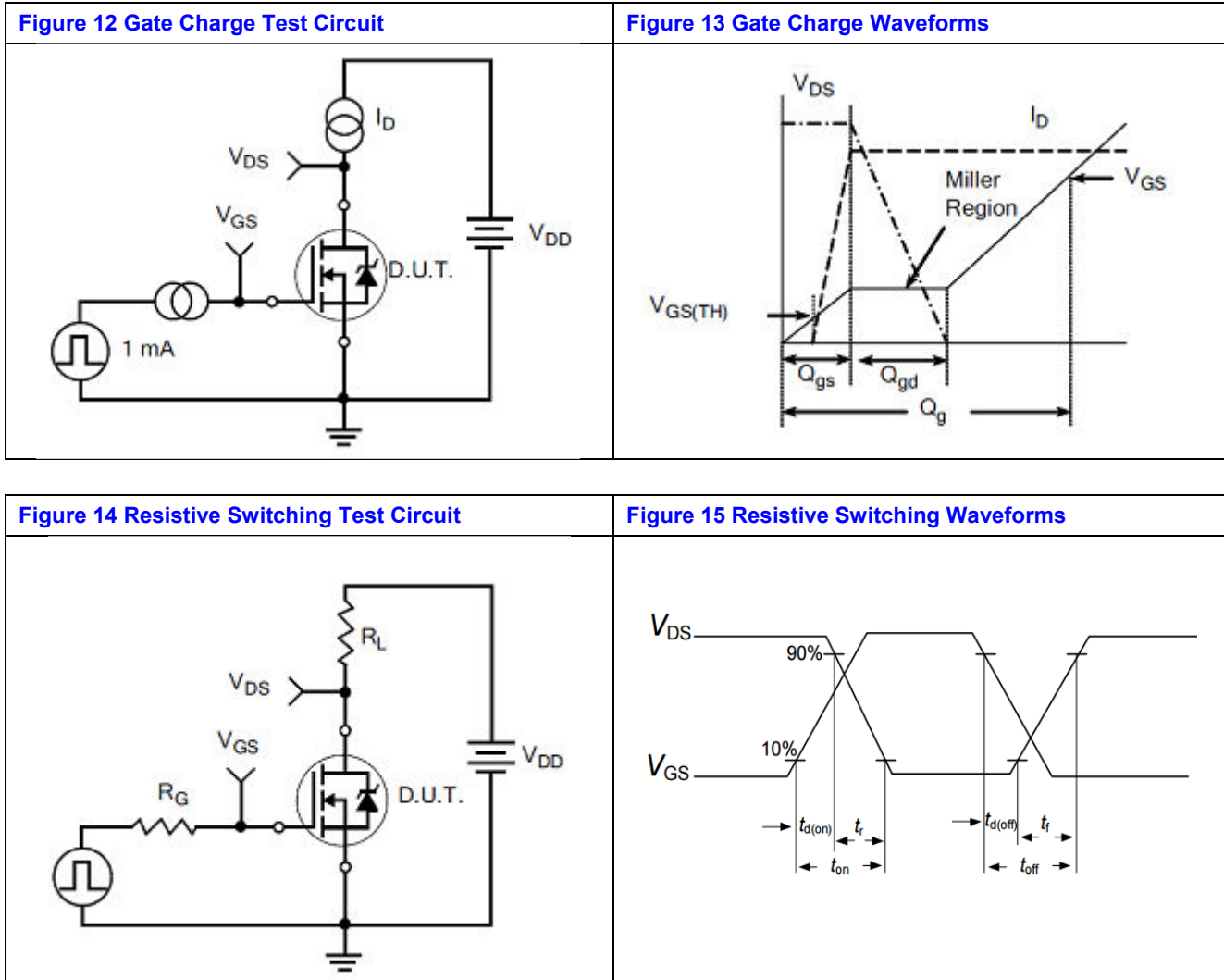

Figure 16 Diode Reverse Recovery Test Circuit

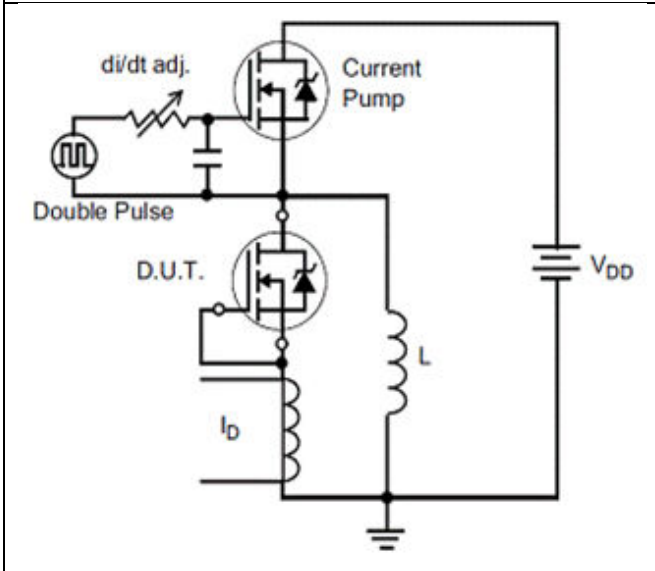

Figure 17 Diode Reverse Recovery Waveform

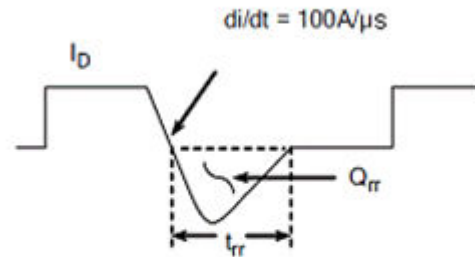

Figure 18 Unclamped Inductive Switching Test Circuit

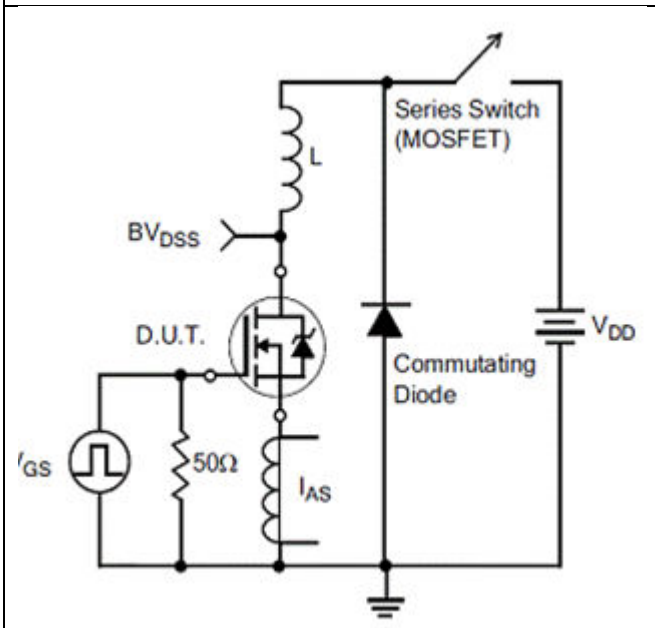
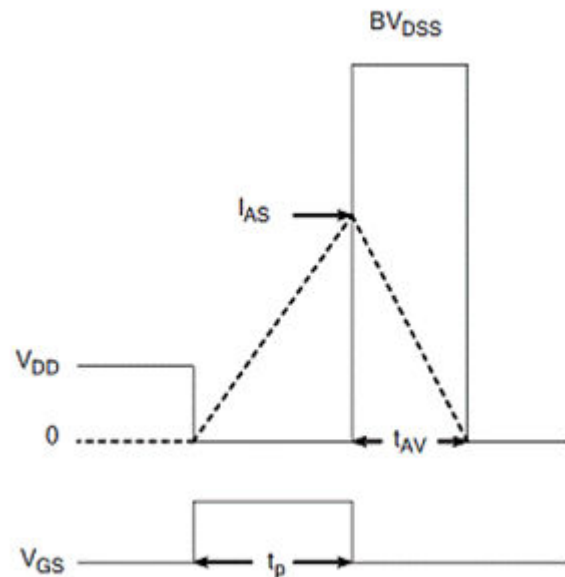
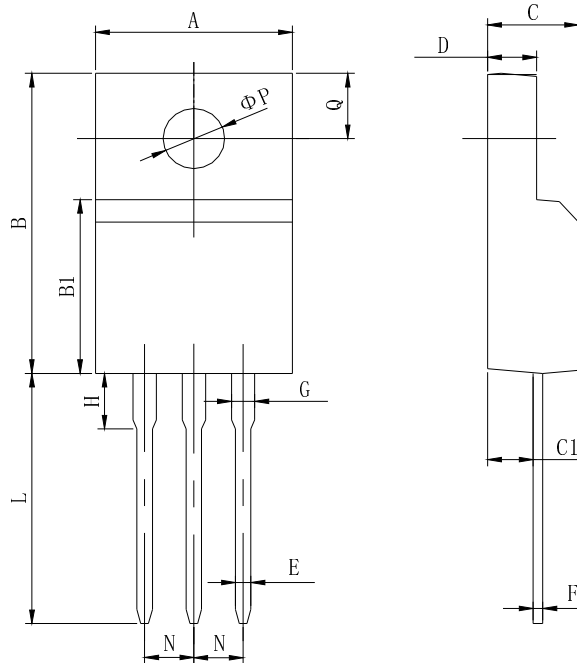

Figure 19 Unclamped Inductive Switching Waveform



7. Package Description



| Items | Values(mm) | |
|----------|------------|------|
| | MIN | MAX |
| A | 9.60 | 10.4 |
| B | 15.4 | 16.2 |
| B1 | 8.90 | 9.50 |
| C | 4.30 | 4.90 |
| C1 | 2.10 | 3.00 |
| D | 2.40 | 3.00 |
| E | 0.60 | 1.00 |
| F | 0.30 | 0.60 |
| G | 1.12 | 1.42 |
| H | 3.40 | 3.80 |
| | 1.60 | 2.90 |
| L | 12.0 | 14.0 |
| N | 2.34 | 2.74 |
| Q | 3.15 | 3.55 |
| ϕP | 2.90 | 3.30 |

TO-220F Package

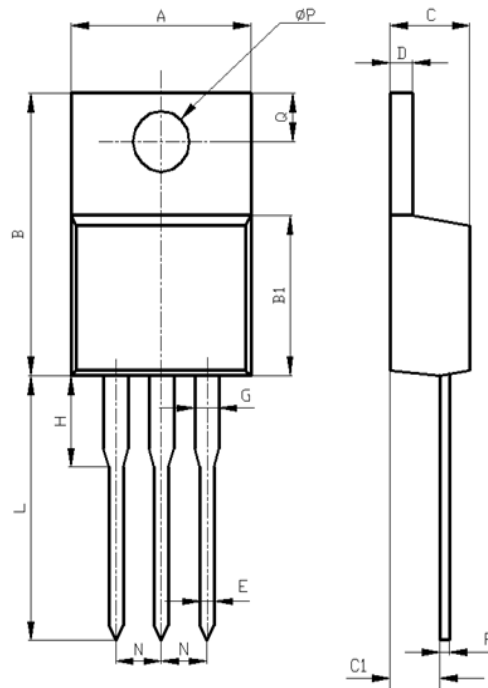

| Items | Values(mm) | |
|-------|------------|------|
| | MIN | MAX |
| A | 9.60 | 10.6 |
| B | 15.0 | 16.0 |
| B1 | 8.90 | 9.50 |
| C | 4.30 | 4.80 |
| C1 | 2.30 | 3.10 |
| D | 1.20 | 1.40 |
| E | 0.70 | 0.90 |
| F | 0.30 | 0.60 |
| G | 1.17 | 1.37 |
| H | 2.70 | 3.80 |
| L | 12.6 | 14.8 |
| N | 2.34 | 2.74 |
| Q | 2.40 | 3.00 |
| Φ P | 3.50 | 3.90 |

TO-220 Package

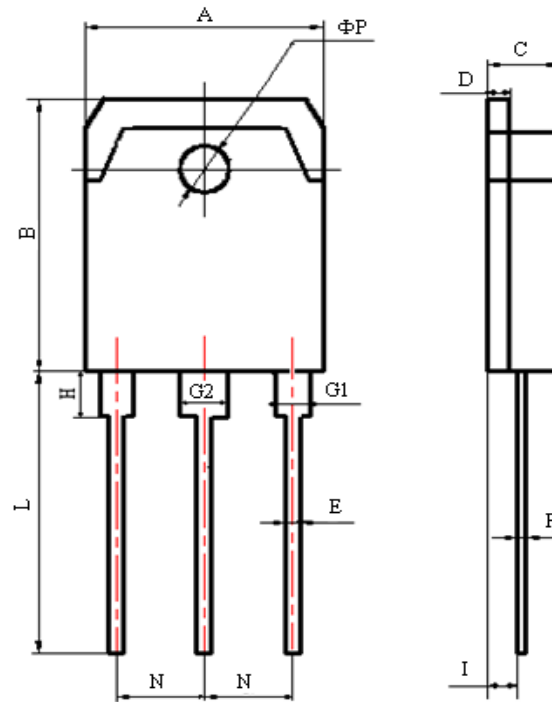

| Items | Values(mm) | |
|-------|------------|-------|
| | MIN | MAX |
| A | 15.00 | 16.00 |
| B | 19.20 | 20.60 |
| C | 4.60 | 5.00 |
| D | 1.40 | 1.60 |
| E | 0.90 | 1.10 |
| F | 0.50 | 0.70 |
| G1 | 2.00 | 2.20 |
| G2 | 3.00 | 3.20 |
| H | 3.00 | 3.70 |
| I | 1.20 | 1.70 |
| | 2.70 | 2.90 |
| L | 19.00 | 21.00 |
| N | 5.25 | 5.65 |
| Φ P | 3.10 | 3.30 |

TO-3PN Package

NOTE:

1. Exceeding the maximum ratings of the device in performance may cause damage to the device, even the permanent failure, which may affect the dependability of the machine. Please do not exceed the absolute maximum ratings of the device when circuit designing.
2. When installing the heat sink, please pay attention to the torsional moment and the smoothness of the heat sink.
3. MOSFETs is the device which is sensitive to the static electricity, it is necessary to protect the device from being damaged by the static electricity when using it.
4. Shanghai Belling reserves the right to make changes in this specification sheet and is subject to change without prior notice.

CONTACT:

上海贝岭股份有限公司（总部）

地址：上海市宜山路 810 号

邮编：200233

电话：021-24261000

产品业务咨询及技术支持

电话：021-24261326

传真 2：021-64852222

邮箱 2：marketing@belling.com.cn

上海贝岭深圳分公司（华南区）

地址：深圳市福田区中心区民田路新华保险大厦 1510 室

邮编：518031

电话：0755-33336776 0755-33336770

传真：0755-33336788

上海贝岭北京办事处（华北区）

地址：北京市西城区新华里 16 号院锦官苑小区 10 号楼 1 单元 1505 室

邮编：100044

电话：010-64179374

传真：010-8835 9236